

ELIMINATOR[®]

LIGHTING

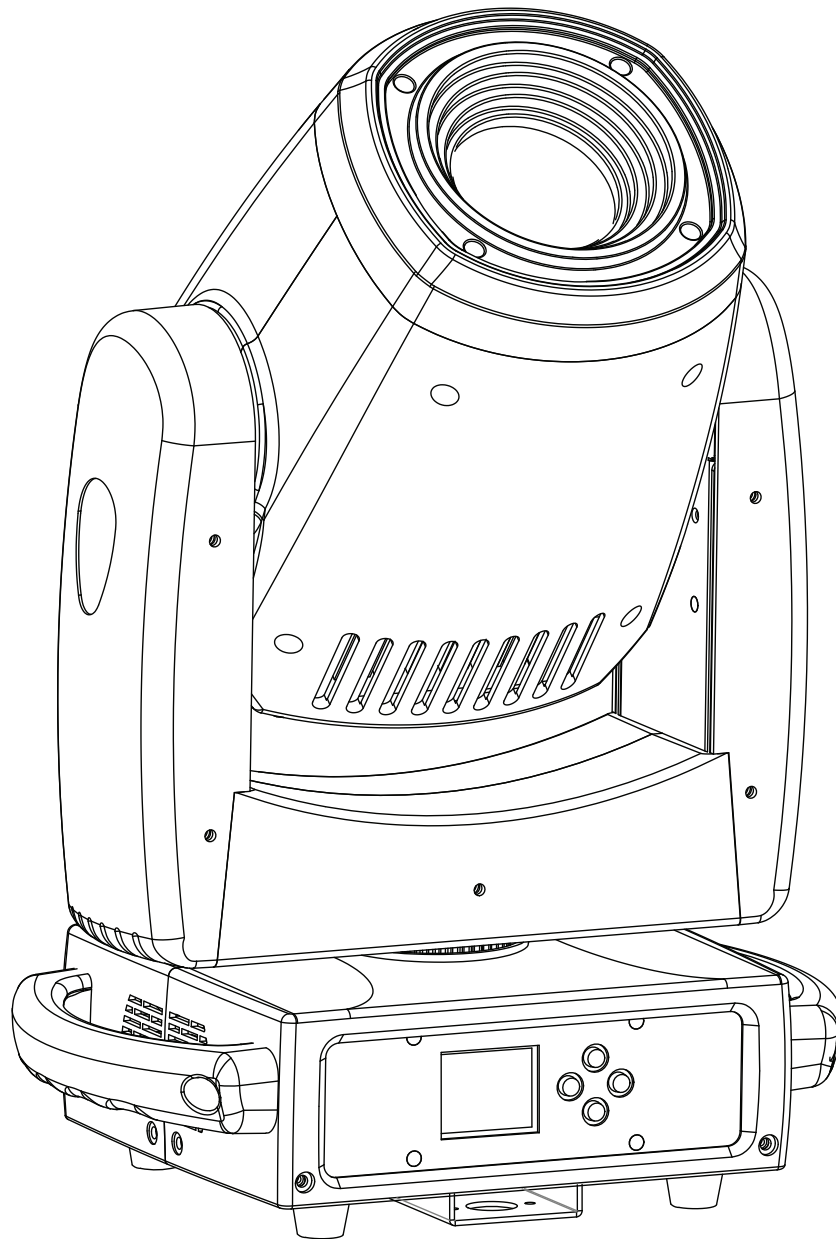

STRYKER SPOT

User Manual

©2024 **Eliminator Lighting** all rights reserved. Information, specifications, diagrams, images, and instructions herein are subject to change without notice. Eliminator logo and identifying product names and numbers herein are trademarks of Eliminator Lighting. Copyright protection claimed includes all forms and matters of copyrightable materials and information now allowed by statutory or judicial law or hereinafter granted. Product names used in this document may be trademarks or registered trademarks of their respective companies and are hereby acknowledged. All non-Eliminator brands and product names are trademarks or registered trademarks of their respective companies.

Eliminator Lighting and all affiliated companies hereby disclaim any and all liabilities for property, equipment, building, and electrical damages, injuries to any persons, and direct or indirect economic loss associated with the use or reliance of any information contained within this document, and/or as a result of the improper, unsafe, insufficient and negligent assembly, installation, rigging, and operation of this product.

Eliminator Lighting

6122 S. Eastern Ave. Los Angeles, CA. 90040
323-582-2650 | Fax 323-532-2941 | www.adj.com | info@adj.com

ADJ SUPPLY Europe B.V

Junostraat 2 6468 EW Kerkrade, The Netherlands
+31 (0)45 546 85 00 | Fax +31 45 546 85 99
www.adj.eu | info@adj.eu

ADJ PRODUCTS GROUP Mexico

AV Santa Ana 30 Parque Industrial Lerma, Lerma, Mexico 52000
+52 (728) 282-7070

DOCUMENT VERSION



Due to additional product features and/or enhancements, an updated version of this document may be available online. Please check www.adj.com for the latest revision/update of this manual before beginning installation and/or programming.

Date	Document Version	Software Version >	DMX Channel Mode	Notes
01/17/24	1.0	1.13	16 / 18 Ch	Initial release
04/05/24	1.1	N/C	No Change	Updated Overview, Specifications; Added FCC Statement
06/18/24	1.2	1.36	No Change	Updated System Menu, Operating Instructions, DMX Traits, Specifications, FCC Statement

CONTENTS

Introduction	4
Limited Warranty (USA Only)	5
Warranty Registration Features	6
Safety Guidelines	7
Overview	8
Installation	9
Color Wheel Gobos	13
Remote Device Management (RDM)	14
Control Panel	15
System Menu	16
Operating Instructions	19
Target Mode	22
Primary-Secondary Configuration Multi Unit Power Linking	25
DMX Setup	26
DMX Traits	29
Fuse Replacement Cleaning	32
Specifications	33
Dimensional Drawings	34
FCC Statement	36

INTRODUCTION

UNPACKING

Thank you for purchasing the Stryker Spot by Eliminator Lighting. Every unit has been thoroughly tested and has been shipped in perfect operating condition. Carefully check the shipping carton for damage that may have occurred during shipping. If the carton appears to be damaged, carefully inspect your fixture for any damage and be sure all accessories necessary to operate the unit have arrived intact. In the event that damage is found or parts are missing, please contact our toll free customer support number for further instructions. Do not return this unit to your dealer without first contacting customer support.

INTRODUCTION

This device is a DMX intelligent, LED powered moving head fixture, and can be used in stand alone mode or connected in a primary/secondary configuration. This wash has four operating modes: DMX control mode, primary-secondary mode, auto run mode, and sound mode. To optimize the performance of this product, please read these operating instructions carefully to familiarize yourself with the basic operations of this unit. These instructions contain important safety information regarding the use and maintenance of this unit. Please keep this manual with the unit for future reference.

CUSTOMER SUPPORT

Tel: (323) 213-4592 | Fax: (323) 582-2941

www.adj.com | support@eliminatorlighting.com

Warning! To prevent or reduce the risk of electrical shock or fire, do not expose this unit to rain or moisture.

Caution! There are no user serviceable parts inside this unit. Do not attempt any repairs yourself, as doing so will void your manufacturer's warranty. In the event that your unit requires service, please contact Eliminator Lighting for assistance.

PLEASE recycle the shipping carton when ever possible.

LIMITED WARRANTY (USA ONLY)

- A. Eliminator Lighting, an ADJ Products, LLC brand, hereby warrants, to the original purchaser, Eliminator Lighting products to be free of manufacturing defects in material and workmanship for a prescribed period from the date of purchase (see specific warranty period on reverse). This warranty shall be valid only if the product is purchased within the United States of America, including possessions and territories. It is the owner's responsibility to establish the date and place of purchase by acceptable evidence, at the time service is sought.
- B. For warranty service, you must obtain a Return Authorization number (RA#) before sending back the product—please contact ADJ Products, LLC Service Department at 800-322-6337. Send the product only to the Eliminator Lighting factory. All shipping charges must be pre-paid. If the requested repairs or service (including parts replacement) are within the terms of this warranty, Eliminator Lighting will pay return shipping charges only to a designated point within the United States. If the entire instrument is sent, it must be shipped in its original package. No accessories should be shipped with the product. If any accessories are shipped with the product, Eliminator Lighting shall have no liability whatsoever for loss of or damage to any such accessories, or for the safe return thereof.
- C. This warranty is void if the serial number has been altered or removed; if the product is modified in any manner which Eliminator Lighting concludes, after inspection, affects the reliability of the product, if the product has been repaired or service by anyone other than ADJ Products, LLC factory unless prior written authorization was issued to purchaser by Eliminator Lighting; if the product is damaged because not properly maintained as set forth in the instruction manual.
- D. This is not a service contract, and this warranty does not include maintenance, cleaning or periodic check up. During the period specified above, Eliminator Lighting will replace defective parts at its expense with new or refurbished parts, and will absorb all expenses for warranty service and repair labor by reason of defects in material or workmanship. The sole responsibility of Eliminator Lighting under this warranty shall be limited to the repair of the product, or replacement thereof, including parts, at the sole discretion of Eliminator Lighting. All products covered by this warranty were manufactured after August 15, 2012, and bear identifying marks to that effect.
- E. Eliminator Lighting reserves the right to make changes in design and/or improvements upon its products without any obligation to include these changes in any products theretofore manufactured.
- F. No warranty, whether expressed or implied, is given or made with respect to any accessory supplied with products described above. Except to the extent prohibited by applicable law, all implied warranties made by Eliminator Lighting in connection with this product, including warranties of merchantability or fitness, are limited in duration to the warranty period set forth above. And no warranties, whether expressed or implied, including warranties of merchantability or fitness, shall apply to this product after said period has expired. The consumer's and/or Dealer's sole remedy shall be such repair or replacement as is expressly provided above; and under no circumstances shall Eliminator Lighting be liable for any loss or damage, direct or consequential, arising out of the use of, or inability to use, this product.
- G. This warranty is the only written warranty applicable to Eliminator Lighting products and supersedes all prior warranties and written descriptions of warranty terms and conditions heretofore published.

MANUFACTURER'S LIMITED WARRANTY PERIODS

- **Non L.E.D. Eliminator Lighting products** = 1-year (365 days) Limited Warranty (Such as: Special Effect Lighting, Intelligent Lighting, UV lighting, Strobes, Fog Machines, Bubble Machines, Mirror Balls, Par Cans, Trussing, Lighting Stands etc., excluding lamps)
- **L.E.D. Eliminator Lighting Products** = 2-year (730 days) Limited Warranty (excluding batteries which have a 180 day limited warranty). Note: 2 Year Warranty only applies to purchases within the United States.
- **Eliminator Laser Products** = 1 Year (365 Days) Limited Warranty (excluding laser diodes which have a 6 month limited warranty)

WARRANTY REGISTRATION

This device carries a 2 year limited warranty. Please fill out the enclosed warranty card to validate your purchase. All returned service items, whether under warranty or not, must be freight pre-paid and accompanied by a return authorization (R.A.) number. The R.A. number must be clearly written on the outside of the return package. A brief description of the problem as well as the R.A. number must also be written down on a piece of paper included in the shipping carton. If the unit is under warranty, you must provide a copy of your proof of purchase invoice. You may obtain an R.A. number by contacting our customer support team on our customer support number. All packages returned to the service department not displaying an R.A. number on the outside of the package will be returned to the shipper.

FEATURES

- 7 Colors + Open
- Four Operating Modes
- Built in Microphone
- DMX Control - 16 or 18 channels
- 3-Pin DMX Connection
- 8 Static Gobos + 6 Rotating Gobos
- Effect Wheel with multiple prism effect modes and bi-directional rotation
- Electronic Focus
- LCD Display

SAFETY GUIDELINES

- To reduce the risk of electrical shock or fire, do not expose this unit to rain or moisture
- Do not spill water or other liquids into or on to your unit.
- Do not attempt to operate this unit if the power cord has been frayed or broken.
- Do not attempt to remove or break off the ground prong from the electrical cord. This prong is used to reduce the risk of electrical shock and fire in case of an internal short.
- Disconnect from main power before making any type of connection.
- Do not remove the cover for any reason. There are no user serviceable parts inside.
- Never operate this unit with the cover removed.
- Never plug this unit in to a dimmer pack.
- Always be sure to mount this unit in an area that will allow proper ventilation. Allow about 6” (15cm) between this device and a wall.
- Do not attempt to operate this unit if it has been damaged in any way.
- This unit is intended for indoor use only, and use of this product outdoors voids all warranties.
- During long periods of non-use, disconnect the unit from main power.
- Always mount this unit in safe and stable matter.
- Power-supply cords should be routed so that they are not likely to be walked on or pinched by items placed upon or against them, paying particular attention to the point at which they exit from the unit.
- Cleaning - The fixture should be cleaned only as recommended by the manufacturer. See the **Cleaning** section of this manual for details.
- Heat - The appliance should be situated away from heat sources such as radiators, heat registers, stoves, or other appliances (including amplifiers) that produce heat.
- The fixture should be serviced by qualified service personnel when:
 - A. The power-supply cord or the plug has been damaged.
 - B. Objects have fallen onto, or liquid has been spilled into, the appliance.
 - C. The appliance has been exposed to rain or water.
 - D. The appliance does not appear to operate normally or exhibits a marked change in performance.

OVERVIEW

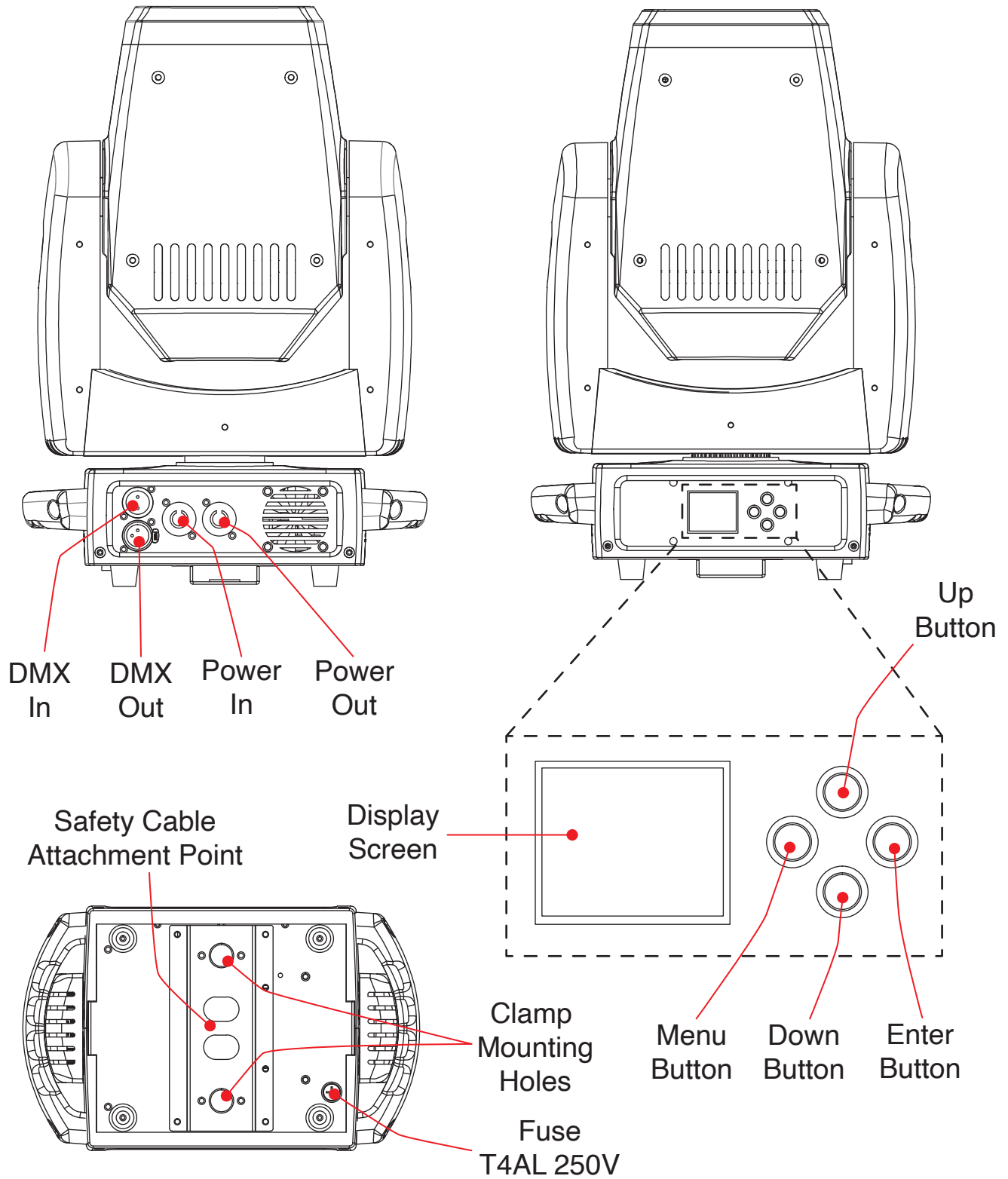

INSTALLATION



DO NOT INSTALL THE FIXTURE IF YOU ARE NOT QUALIFIED TO DO SO!

Fixture **MUST** be installed following all local, national, and country commercial electrical and construction codes and regulations.

When installing the unit, the trussing or area of installation must be able to hold 10 times the weight of the unit and any attached accessories without any deformation. The unit must be secured with a secondary safety attachment, e.g. an appropriately-rated safety cable.

Before rigging/mounting a single fixture to any metal truss/structure or placing the fixture(s) on any surface, a professional equipment installer **MUST** be consulted to determine if the metal truss/structure or surface is properly certified to safely hold the combined weight of the fixture(s), clamps, cables, and accessories.

Maximum ambient operating temperature is **113°F (45°C)**.

Fixture(s) should be installed away from walking paths, seating areas, or areas where unauthorized personnel might reach the fixture by hand.

NEVER stand directly below the fixture(s) when rigging, removing, or servicing.

Overhead fixture installation must always be secured with a secondary safety attachment, such as an appropriately rated safety cable that can hold 10 times the weight of the fixture.

Overhead mounting requires extensive experience, including calculating working load limits, knowledge of installation material being used, and periodic safety inspection of all installation material as well as the unit itself. If you lack these qualifications, do not attempt the installation yourself.

The installation should be checked by a skilled person once a year.

INSTALLATION

CLAMP MOUNTING

This fixture features mounting holes on the underside of the base for the installation of a mounting bracket and clamp. To install a mounting clamp, attach the clamp to the included Omega bracket by inserting an appropriately rated bolt through the clamp and Omega bracket, and secure in place with a matching nut and washer. Insert the Omega bracket's twist lock fasteners into the fixture's outer mounting holes, then twist the fasteners to lock in place (see the illustration below). Attach a SAFETY CABLE of the appropriate rating through the two central holes on the underside of the fixture, and secure the cable around the truss.

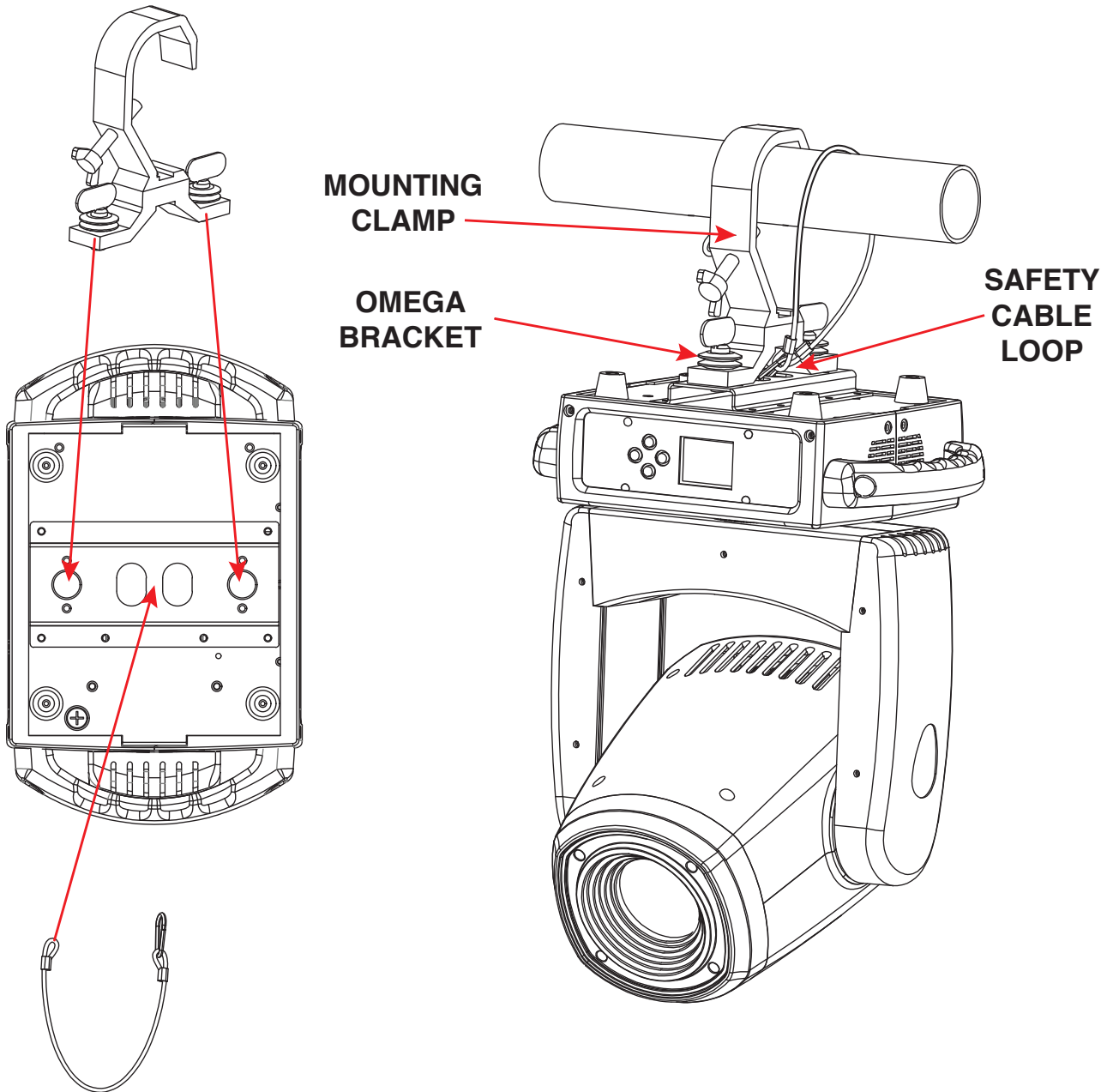

SAFETY CABLE:

ALWAYS ATTACH A SAFETY CABLE WHENEVER INSTALLING THIS FIXTURE IN A SUSPENDED ENVIRONMENT TO ENSURE THAT THE FIXTURE WILL NOT FALL IF THE CLAMP FAILS.



INSTALLATION

This unit should be mounted using a mounting clamp (not provided) and affixing it to the mounting bracket that is provided with the unit. Always ensure that the unit is firmly fixed in order to avoid vibration and slipping during operation. Always ensure that the structure to which you are attaching the unit is secure and is able to support at least 10 times the unit's weight. Also, always use a safety cable that can support at least 12 times the weight of the unit when installing the fixture. The equipment must be installed by a professional, and it must be installed in a place where it is out of the reach of the general public.

The unit is fully operational in three different mounting positions: hanging upside-down from the ceiling or trussing, sideways on trussing, or set on a flat level surface. Be sure this fixture is kept at least 12m (40ft) away from any flammable materials (decorations, etc). Always use and install a safety cable (not included) as a safety measure to prevent accidental damage and/or injury in the event the clamp fails.

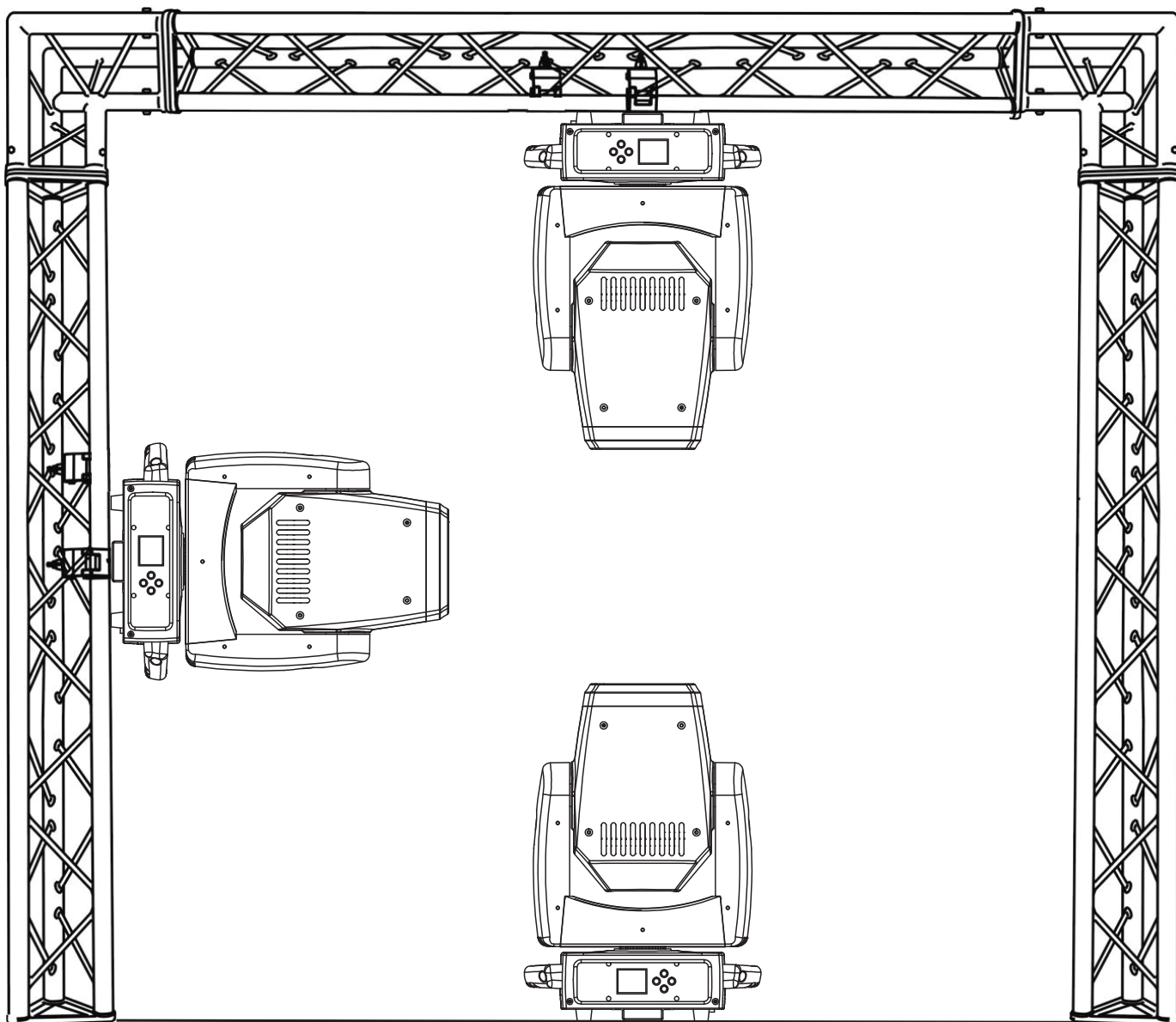

INSTALLATION

POTENTIAL INTERNAL FIXTURE DAMAGE FROM EXTERNAL SOURCES OF LIGHT BEAMS

External sources of light beams from direct sunlight, lighting and moving head fixtures, and lasers, which are focused directly towards the exterior housing and/or penetrate the front lens opening of Eliminator lighting fixtures, can cause severe internal damage including burning of optics, dichroic color filters, glass and metal gobos, prisms, animation wheels, frost filters, iris, shutters, motors, belts, wiring, discharge lamps, and LEDs.

This issue is not specific only to Eliminator lighting fixtures, but rather it is a common issue with lighting fixtures from all manufacturers. Although there is no true way to fully prevent this issue from happening, the guidelines below can reduce the risk of potential damage. Contact Eliminator Service for more details.

DO NOT EXPOSE THE FIXTURE AND/OR FRONT LENS OPENING TO LIGHT BEAMS FROM DIRECT SUNLIGHT, OTHER LIGHTING OR MOVING HEAD FIXTURES, AND LASERS DURING UNPACKING, INSTALLATION, USE, AND EXTENDED IDLE TIMES OUTDOORS. DO NOT FOCUS A LIGHT BEAM FROM ONE LIGHTING FIXTURE DIRECTLY TOWARDS ANOTHER.

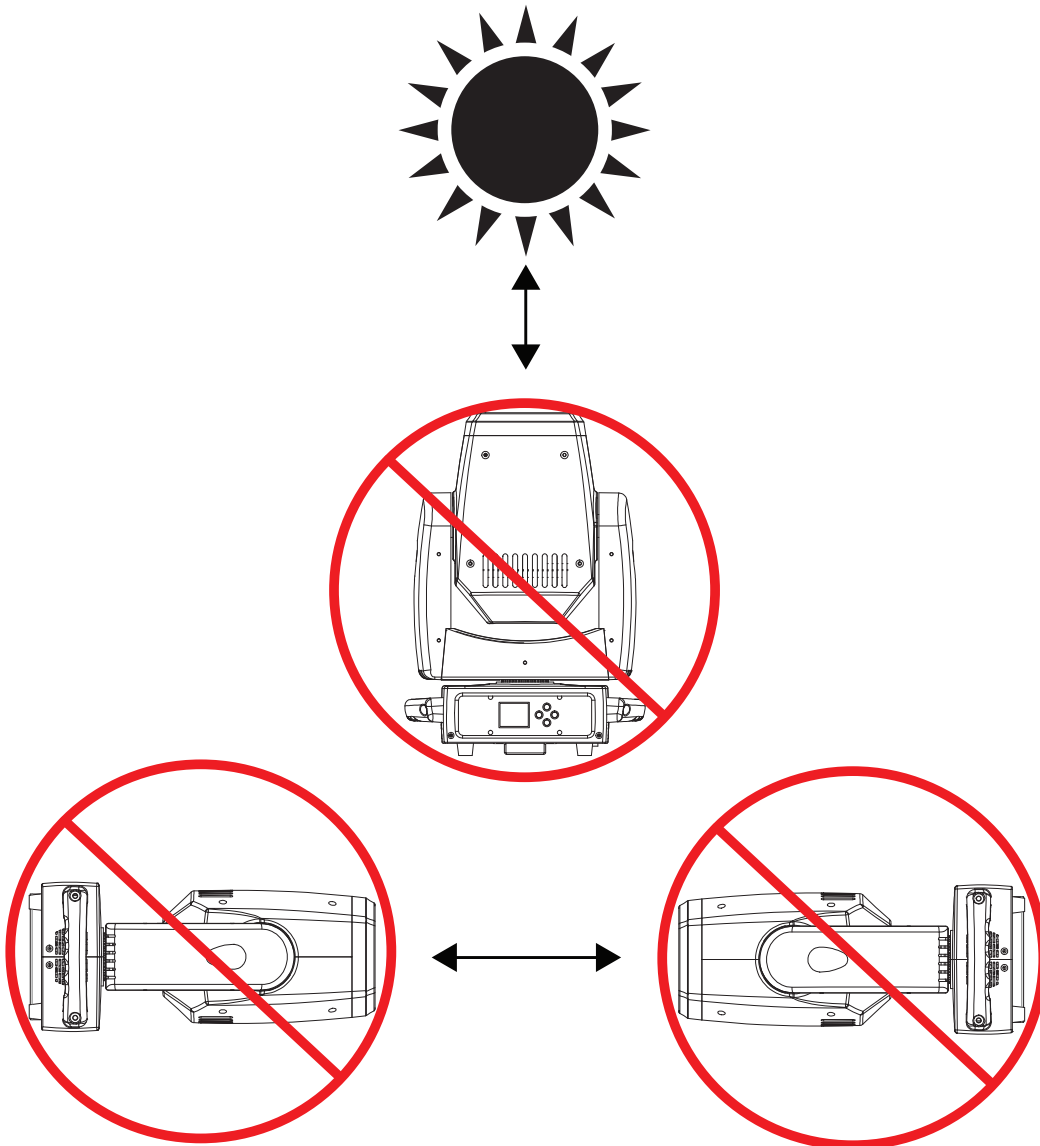

COLOR WHEEL

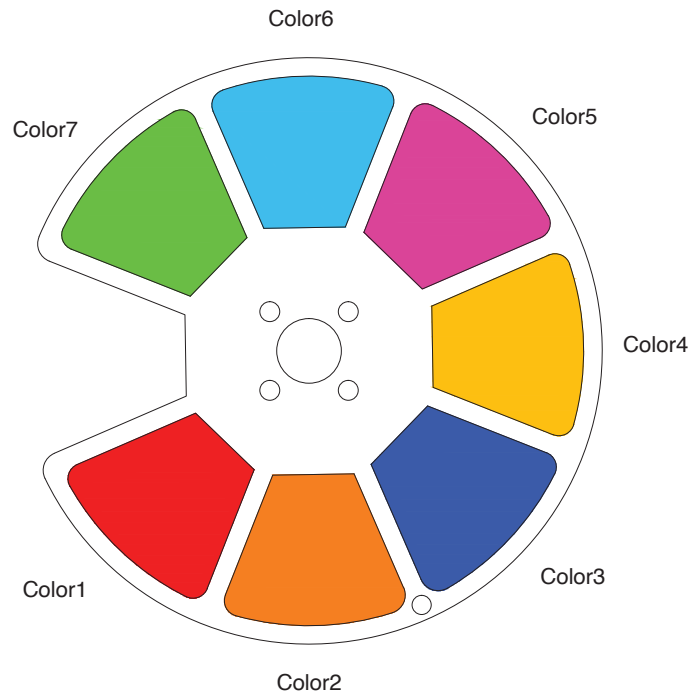

GOBOS

GOBO WHEEL 1 - FIXED GOBOS

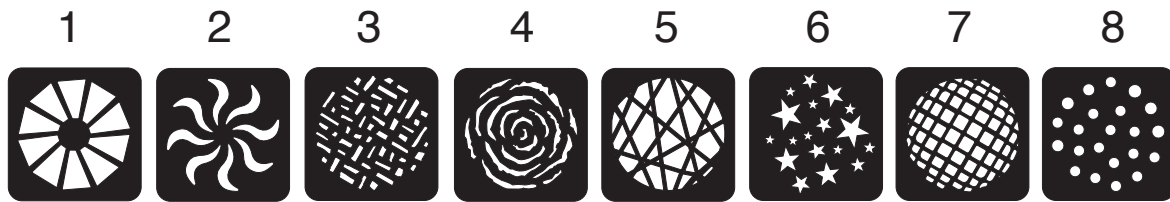

GOBO WHEEL 2 - ROTATING GOBOS



REMOTE DEVICE MANAGEMENT (RDM)

NOTE: In order for RDM to work properly, RDM enabled equipment must be used throughout the entire system, including DMX data splitters and wireless systems.

Remote Device Management (RDM) is a protocol that sits on top of the DMX512 data standard for lighting, allowing the DMX systems of the fixtures to be modified and monitored remotely. This protocol is ideal for instances in which a unit is installed in a location that is not easily accessible.

With RDM, the DMX512 system becomes bi-directional, allowing a compatible RDM enabled controller to send out a signal to devices on the wire, as well as allowing the fixture to respond (known as a *GET* command). The controller can then use its *SET* command to modify settings that would typically have to be changed or viewed directly via the unit's display screen, including the DMX Address, DMX Channel Mode, and Temperature Sensors.

FIXTURE RDM INFORMATION:

RDM Code	Device ID	Device Model ID	Personality ID
0x6666	Random	H7A	CH16 (1) CH18 (2)

Please be aware that not all RDM devices support all RDM features, and therefore it is important to check beforehand to ensure that the equipment that you are considering includes all of the features that you require.

[0x00F0] DMX Start Address
[0x1000] Identify
[0x0001] Disc Unique Branch
[0x0002] Disc Mute
[0x0003] Disc Un Mute
[0x00E1] DMX Personality Description
[0x00E0] DMX Personality
[0x0082] Device Label
[0x0081] Manufacturer Label
[0x0080] Device Model Description
[0x0060] Device Info

CONTROL PANEL

This fixture features a display screen with a 4-button control pad, which can be used to easily adjust any device settings.

Pressing the MENU button will cycle through the various Main Menu options. When the desired Main Menu option is displayed on the screen, press the ENTER button to enter the sub-menu, then use the UP and DOWN buttons to scroll through sub-menu options. In some cases, there will be a second sub-menu that can be navigated in the same way.

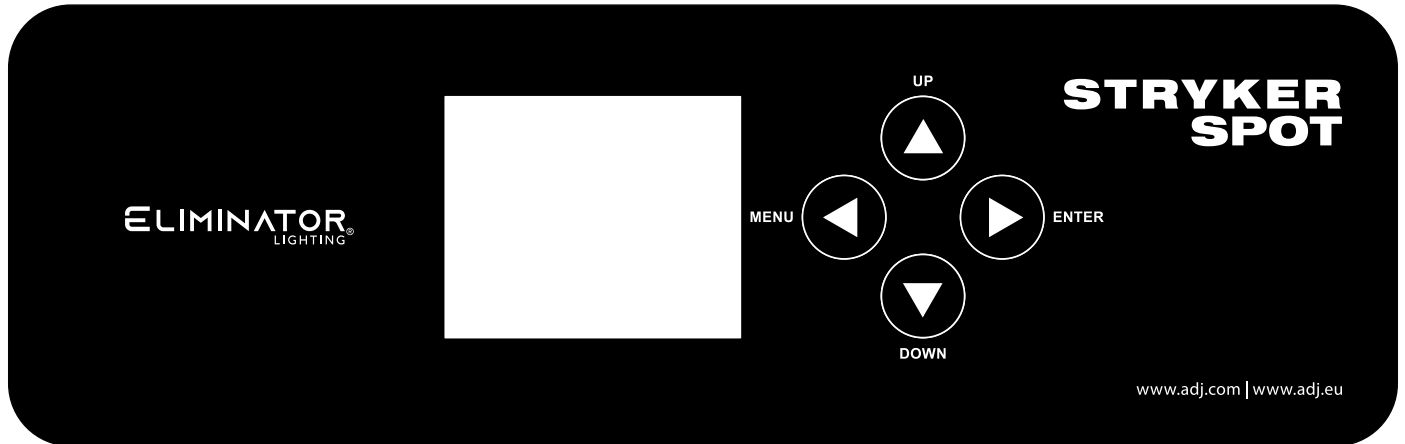

SYSTEM MENU

DMX SETTINGS	Address	001 - 512		Set DMX address
	Mode	16 Ch		Select DMX channel mode
		18 Ch		
	No DMX	Hold		Holds last settings received if DMX signal is lost or interrupted
Program / Auto		Defaults to selected Program settings if DMX signal is lost or interrupted		
Sound		Defaults to Sound Active mode if DMX signal is lost or interrupted		
PERSONALITY	Pri/Sec Mode	Primary / Secondary		Set unit to operate in primary or secondary mode
	Aria Settings	Set Aria Band	2.4 Ghz	Select Aria frequency band
			Subgig (US)	
			Subgig (EU)	
		Aria 2.4Ghz channel	00 - 15	Set 2.4 GHz Aria channel
		Aria Subgig channel	00 - 09	Set subgig channel
		Mesh	On / Off	Enable or disable mesh
	Bluetooth Enable	On / Off	Enable or disable Bluetooth	
	Pan Invert	Yes / No		Invert pan movement
	Tilt Invert	Yes / No		Invert tilt movement
	P/T Correction	On / Off		Enable or disable pan/tilt correction
	Display Reverse	Yes / No		Invert screen display orientation
	Target Mode	Off / On		Enable or disable target mode
	Sound Sensitivity	000 - 100 (Default = 010)		Set sensitivity level
	Reset	Yes / No		Restart fixture
Factory Restore	Passcode = 018	Yes / No	Reset unit to factory default settings	
Calibration	Passcode = 018	All to Origin	Calibrate fixture settings	
		Pan = -128 ~ 127		
		Tilt = -128 ~ 127		
		Color = -128 ~ 127		
		Gobo 1 = -128 ~ 127		
		Gobo 2 = -128 ~ 127		
		...		
		Prism = -128 ~ 127		
Zoom = -128 ~ 127				

SYSTEM MENU

RUN MODE	Program	Program 1	Select target mode program to run
		Program 2	
		Program 3	
		Program 4	
		Program 5	
		Program 6	
		Program 7	
		Program 8	
	Program Speed	1 - 10 (default = 5)	Set target mode program speed; 1 is slowest, 10 is fastest
	Auto Play	Auto Play 1	Select auto play mode to run
Auto Play 2			
Auto Play 3			
Auto Play 4			
Auto Play 5			
Auto Play 6			
Auto Play 7			
Auto Play 8			
Auto Play Speed	1 - 10 (default = 5)	Set auto play speed; 1 is slowest, 10 is fastest	
MANUAL MODE	Pan	000 - 255	Manually control each parameter
	Pan Fine	000 - 255	
	Tilt	000 - 255	
	Tilt Fine	000 - 255	
	Color	000 - 255	
	Gobo 1	000 - 255	
	Gobo 2	000 - 255	
	Gobo 2 Rotation	000 - 255	
	Shutter	000 - 255	
	Dimmer	000 - 255	
	Focus	000 - 255	
	Zoom	000 - 255	
	Prism	000 - 255	
	Prism Rotation	000 - 255	
	Effect Auto	000 - 255	
	Pan/Tilt Auto	000 - 255	
	Pan/Tilt Speed	000 - 255	
	Reset	000 - 255	

SYSTEM MENU

SYS INFO	On Time	xxxxxH xxM	Time that fixture has been powered with LED on
	Total Time	xxxxxH xxM	Total lifetime hours that fixture has been powered on
	Firmware Version	Vx.xxx	Current software version
	Running Mode	DMX xx Ch	Currently selected DMX channel mode
	Temperature	xxx°F	Current fixture temperature

OPERATING INSTRUCTIONS

DMX Address:

Set the DMX address of your device.

1. Press the MENU button until “DMX Settings” is displayed, and press ENTER to select.
2. Use the UP and DOWN buttons to scroll to “Address”, then press the ENTER to select.
3. Use the UP and DOWN buttons to scroll to your desired DMX address, then press ENTER to confirm. Selectable values range from 001 to 512.

DMX Mode:

Operating through a DMX controller gives the user the freedom to create custom programs tailored to their own individual needs. This function also allows you to use your fixtures as spot lights. 2 DMX modes are available: 16 channel mode and 18 channel mode. Refer to the **DMX Traits** section of this manual for detailed information.

1. Press the MENU button until “DMX Settings” is displayed, and press ENTER to select.
2. Use the UP and DOWN buttons to scroll to “Mode”, then press ENTER to select.
3. Use the UP and DOWN buttons to toggle between 16-channel and 18-channel mode, then press ENTER to confirm your selection.

No DMX State:

This setting defines the way the fixture will behave in the event that the DMX signal is lost or interrupted, or which operating mode the unit will return to when power is applied.

1. Press the MENU button until “DMX Settings” is displayed, then press ENTER to select.
2. Use the UP and DOWN buttons to scroll to “No DMX”, then press ENTER to select.
3. Use the UP and DOWN buttons to scroll to the desired No DMX State, then press ENTER to confirm. Selectable options are listed below:
 - *Hold* - The unit holds the last settings received before DMX signal was lost.
 - *Program* - The unit defaults to the designated Program or Auto mode when DMX signal is lost.
 - *Sound* - The unit default to sound active mode when DMX signal is lost.

Personality:

1. Press the MENU button until “Personality” is displayed, and press ENTER to select.
2. Use the UP and DOWN buttons to scroll to through the fixture’s personality parameters, then press ENTER to select. Personality parameters are listed below:
 - *Pri/Sec Mode* - Set the unit as either a primary or secondary unit.
 - *Aria Settings* - Use this menu to configure the unit’s Aria functions, including frequency band, channel, mesh, and Bluetooth.
 - *Pan Invert* - Enable or disable the pan movement.
 - *Tilt Invert* - Enable or disable the tilt movement.
 - *P/T Correction* - Enable or disable pan and tilt correction.
 - *Display Reverse* - Enable or disable inversion of the screen display.
 - *Target Mode* - Enable or disable Target Mode. Please note that target mode program and run speed can be selected by navigating to Run Mode > Program and Run Mode > Program Speed.
 - *Sensitivity* - Set the sensitivity level.
3. Use the UP and DOWN buttons to scroll through the sub-options for each personality parameter, then press ENTER to confirm.

OPERATING INSTRUCTIONS

Reset:

Restart the fixture.

1. Press the MENU button until “Personality” is displayed, and press ENTER to select.
2. Use the UP and DOWN buttons to toggle between “Yes” and “No”, then press ENTER to confirm. Selecting “Yes” restarts the fixture, while selecting “No” will return you to the previous menu without making any changes.

Factory Restore:

Restore all fixture parameters to the default factory settings.

1. Press the MENU button until “Personality” is displayed, then press ENTER to select.
2. Use the UP and DOWN buttons to scroll to “Factory Restore”, then press ENTER to select.
3. Use the UP and DOWN buttons to scroll to the password (“018”) and press ENTER to confirm. The fixture will now reset to the default factory settings.

Calibration:

Manually calibrate each individual fixture parameter.

1. Press the MENU button until “Personality” is displayed, then press ENTER to select.
2. Use the UP and DOWN buttons to scroll to “Calibration”, then press ENTER to select.
3. Use the UP and DOWN buttons to scroll to the password (“018”) and press ENTER to confirm.
4. Use the UP and DOWN buttons to scroll to the parameter you wish to calibrate, then press ENTER to select.
5. Use the UP and DOWN buttons to scroll to the desired value for the selected parameter. Selectable values range from -127 to 128.

Program:

Select from 8 built-in programs for Target Mode.

1. Press the MENU button until “Run Mode” is displayed, then press ENTER to select.
2. Use the UP and DOWN buttons to scroll to “Program”, then press ENTER to select.
3. Use the UP and DOWN buttons to scroll through the 8 available built-in programs, then press ENTER to confirm your selection.
4. Return to the “Run Mode” menu, then use the UP and DOWN buttons to scroll to “Program Speed” and press ENTER to select.
5. Use the UP and DOWN buttons to scroll through the program speed levels, and press ENTER to confirm your selection. “1” is the slowest speed, and “10” is the fastest speed.

Auto Play:

Select an Auto Play mode to run.

1. Press the MENU button until “Run Mode” is displayed, then press ENTER to select.
2. Use the UP and DOWN buttons to scroll to “Auto Play”, then press ENTER to select.
3. Use the UP and DOWN buttons to scroll through the 8 available built-in auto play modes, then press ENTER to confirm your selection.
4. Return to the “Run Mode” menu, then use the UP and DOWN buttons to scroll to “Auto Play Speed” and press ENTER to select.
5. Use the UP and DOWN buttons to scroll through the auto play speed levels, and press ENTER to confirm your selection. “1” is the slowest speed, and “10” is the fastest speed.

OPERATING INSTRUCTIONS

Manual Mode:

Manually control the different fixture parameters.

1. Press the MENU button until “Manual Mode” is displayed, then press ENTER to select.
2. Use the UP and DOWN buttons to scroll through the various parameters: Pan, Pan Fine, Tilt, Tilt Fine, Color, Gobo 1, Gobo 2, Gobo 2 Rotation, Shutter, Dimmer, Focus, Zoom, Prism, Sound Sensitivity, Effect Auto, Pan/Tilt Auto, Pan/Tilt Speed, and Reset. Press ENTER to confirm your selection.
3. Use the UP and DOWN buttons to set the value for the selected parameter. All parameters have a selectable range of 000 to 255. Press ENTER to confirm your choice.
4. Repeat steps 1-3 for all parameters that you wish to adjust.

On Time:

Display the time that the fixture has been running with the LED on.

1. Press the MENU button until “Sys Info” is displayed, then press ENTER to select.
2. Use the UP and DOWN buttons to scroll to “On Time”, then press ENTER to select.
3. The screen will now display the number of hours and minutes that the fixture has been running with the LED on.

Total Time:

Display the lifetime hours that the fixture has been running.

1. Press the MENU button until “Sys Info” is displayed, then press ENTER to select.
2. Use the UP and DOWN buttons to scroll to “Total Time”, then press ENTER to select.
3. The screen will now display the number of hours and minutes that the fixture has been running for its entire lifetime. This value is NOT resettable.

Firmware Version:

Display the current software version.

1. Press the MENU button until “Sys Info” is displayed, then press ENTER to select.
2. Use the UP and DOWN buttons to scroll to “Firmware Version”, then press ENTER to select.
3. The screen will now display the current software version running on the fixture.

Running Mode:

Display the currently selected DMX channel mode.

1. Press the MENU button until “Sys Info” is displayed, then press ENTER to select.
2. Use the UP and DOWN buttons to scroll to “Running Mode”, then press ENTER to select.
3. The screen will now display the currently selected DMX channel mode.

Temperature:

Display the currently temperature of the fixture.

1. Press the MENU button until “Sys Info” is displayed, then press ENTER to select.
2. Use the UP and DOWN buttons to scroll to “Temperature”, then press ENTER to select.
3. The screen will now display the current temperature of the fixture, in degree Fahrenheit.

TARGET MODE

Target Mode is a special operational mode that restricts the pan and tilt movement of the fixture to a desired range. To enable Target Mode, navigate to Personality > Target Mode, then set this to “On”. Then, select your desired target mode program by navigating to Run Mode > Program, and then selecting from the 8 available options. The details of the target mode programs are shown in the table below:

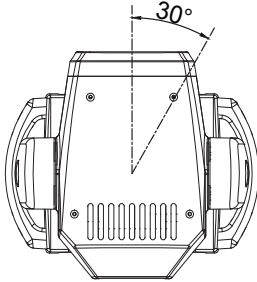
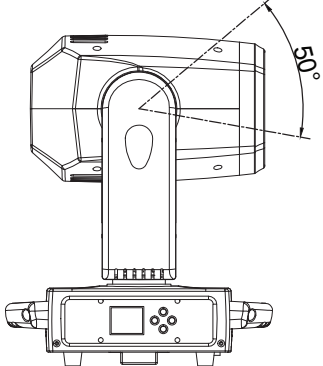
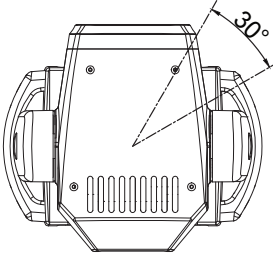
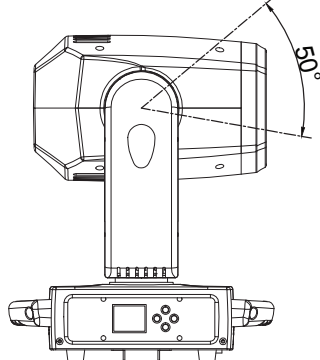
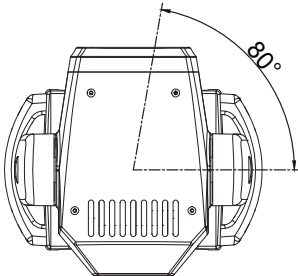
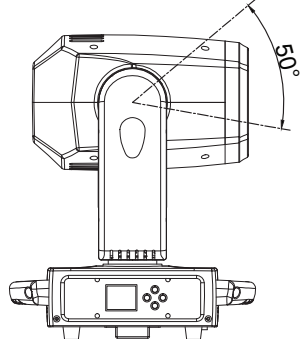
<p>Program 1</p> <p>Pan Movement Range=30°</p>  <p>Display</p>	<p>Tilt Movement Range=50°</p>  <p>Display</p>
<p>Program 2</p> <p>Pan Movement Range=30°</p>  <p>Display</p>	<p>Tilt Movement Range=50°</p>  <p>Display</p>
<p>Program 3</p> <p>Pan Movement Range=80°</p>  <p>Display</p>	<p>Tilt Movement Range=50°</p>  <p>Display</p>

TARGET MODE

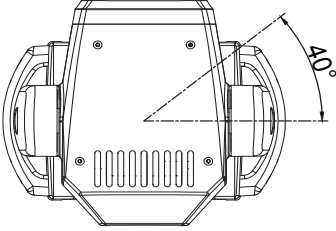
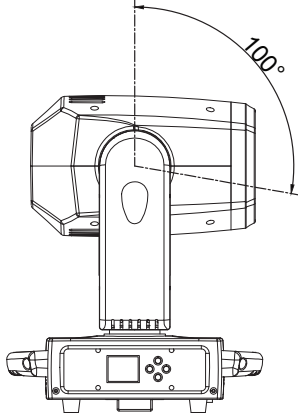
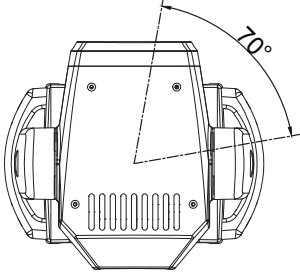
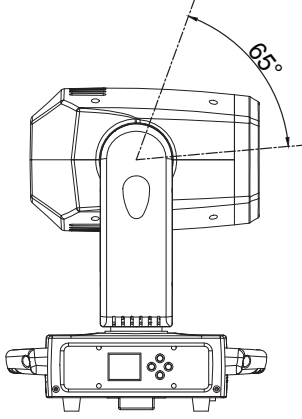
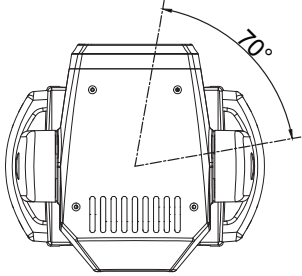
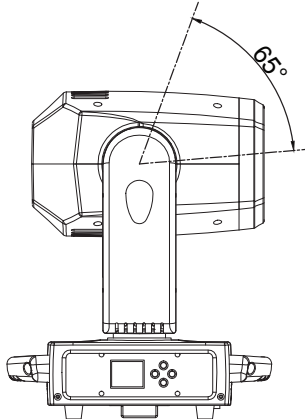
<p>Program 4</p> <p>Pan Movement Range=40°</p>  <p>Display</p>	<p>Tilt Movement Range=100°</p>  <p>Display</p>
<p>Program 5</p> <p>Pan Movement Range=70°</p>  <p>Display</p>	<p>Tilt Movement Range=65°</p>  <p>Display</p>
<p>Program 6</p> <p>Pan Movement Range=70°</p>  <p>Display</p>	<p>Tilt Movement Range=65°</p>  <p>Display</p>

TARGET MODE

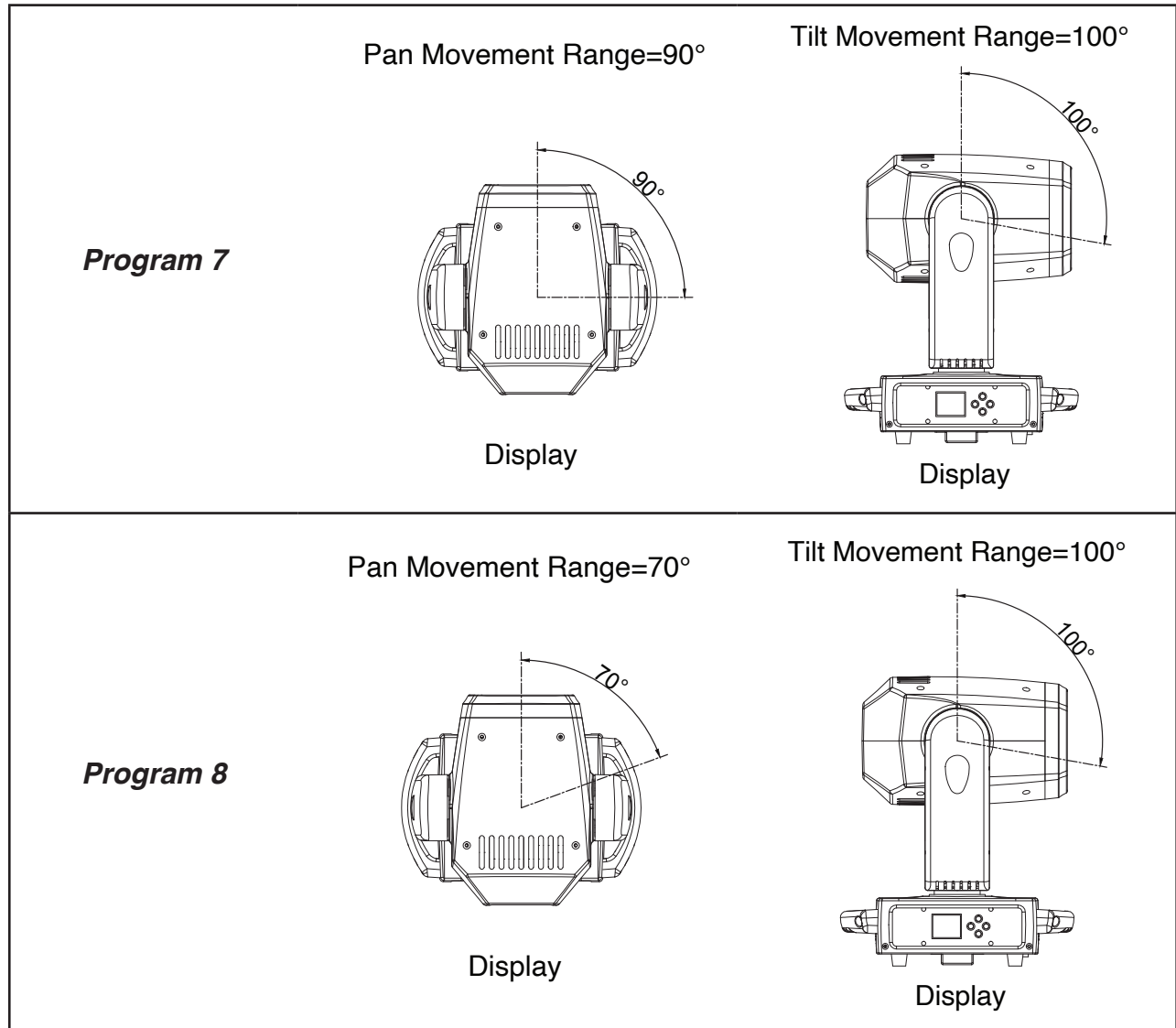

PRIMARY-SECONDARY CONFIGURATION

This function will allow you to link units together to run in a Primary-Secondary set-up, in which one unit will act as the controlling unit, and the others will react to the controlling unit's built-in programs. Any unit can act as a Primary or a Secondary, but only one unit in a given system can be programmed to act as the Primary

Connections and Settings:

1. Daisy chain your units via the XLR connectors on the rear panel of each unit. Use standard XLR data cables to link your units together. Remember that the male XLR connector is the input and the female XLR connector is the output. The first unit in the chain (primary) will use the female XLR connector only, and the last unit in the chain will use the male XLR connector only.
2. In each unit, navigate to Personality > Pri/Sec Mode in the system menu, then press ENTER.
3. Use the UP and DOWN buttons to set each unit as a primary or a secondary, as desired. Remember that only one unit in a given system may be defined as the primary, and all others must be designated as secondaries.
4. Return to your primary unit, and configure the unit as desired. The secondary unit(s) will now follow the programming of the primary unit.

MULTI UNIT POWER LINKING

This feature allows you to connect the fixtures to one another using the power cable input and output sockets.

The maximum number of units that can be linked in this manner is as follows:

- 3 units when running on 120V power.
- 5 units when running on 230V power.

DO NOT EXCEED THIS MAXIMUM NUMBER WHEN POWER LINKING UNITS!

All linked units must be of the same make and model type. Do not mix and match units!

DMX SETUP

DMX-512: DMX is short for Digital Multiplex. This is a universal protocol used as a form of communication between intelligent fixtures and controllers. A DMX controller sends DMX data instructions from the controller to the fixture. DMX data is sent as serial data that travels from fixture to fixture via the DATA “IN” and DATA “OUT” XLR terminals located on all DMX fixtures (most controllers only have a DATA “OUT” terminal).

DMX Linking: DMX is a language allowing all makes and models of different manufacturers to be linked together and operate from a single controller, as long as all fixtures and the controller are DMX compliant. To ensure proper DMX data transmission, try to use the shortest cable path possible when linking several DMX fixtures. The order in which fixtures are connected in a DMX line does not influence the DMX addressing. For example, a fixture assigned a DMX address of 1 may be placed anywhere in a DMX line: at the beginning, at the end, or anywhere in the middle. When a fixture is assigned a DMX address of 1, the DMX controller knows to send DATA assigned to address 1 to that unit, no matter where it is located in the DMX chain.

Data Cable (DMX Cable) Requirements (For DMX Operation): This unit can be controlled via DMX-512 protocol and features 2 selectable DMX modes. Please refer to the **DMX Traits** section of this manual for detailed information. The DMX address can be set using the controls on the rear panel of the unit. Your unit and your DMX controller require a 3-pin XLR connector for data input/output. We recommend Accu-Cable DMX cables. If you are making your own cables, be sure to use standard 110-120 Ohm shielded cable (This cable may be purchased at almost all pro lighting stores). Your cables should be made with a male XLR connector on one end and a female XLR connector on the other. Also remember that DMX cable must be daisy chained and cannot be split.



DMX SETUP

Notice: Be sure to the figures below when making your own cables. Do not use the ground lug on the XLR connector. Do not connect the cable's shield conductor to the ground lug or allow the shield conductor to come in contact with the XLR's outer casing. Grounding the shield could cause a short circuit and erratic behavior.

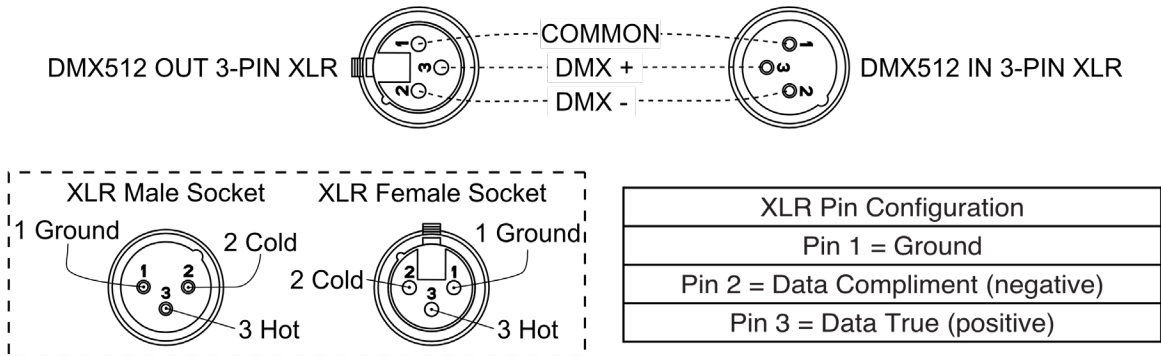

Special Note: Line Termination. When longer runs of cable are used, you may need to use a terminator on the last unit to avoid erratic behavior. A terminator is a 110-120 ohm 1/4 watt resistor which is connected between pins 2 and 3 of a male XLR connector (DATA + and DATA -). This unit is inserted in the female XLR connector of the last unit in your daisy chain to terminate the line. Using a cable terminator (ADJ part number Z-DMX/T) will decrease the possibilities of erratic behavior.

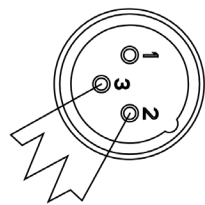

A DMX512 terminator reduces signal errors, avoiding most signal reflection interference. Connect PIN 2 (DMX-) and PIN 3 (DMX+) of the last fixture in series with a 120 Ohm, 1/4 W Resistor to terminate the DMX512.

5-Pin XLR DMX Connectors: Some manufacturers use 5-pin DMX-512 data cables for DATA transmission in place of 3-pin. 5-pin DMX fixtures may be integrated into a 3-pin DMX line with a 5-pin to 3-pin adapter cable. These adapters are readily available at most electronics stores. Follow the chart below for a proper conversion.

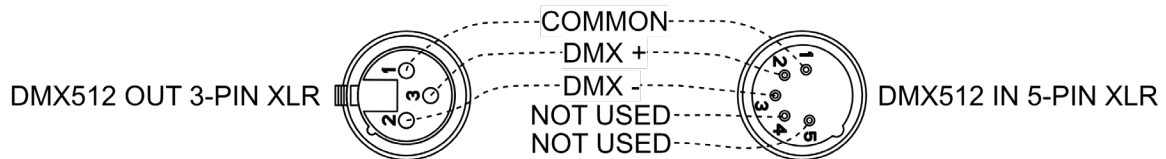

3-Pin XLR to 5-Pin XLR Conversion		
Ground/Shield	Pin 1	Pin 1
Data Compliment (- signal)	Pin 2	Pin 2
Data True (+ signal)	Pin 3	Pin 3
Not Used		Do Not Use
Not Used		Do Not Use

DMX SETUP

DMX Addressing:

All fixtures should be given a DMX starting address when using a DMX controller, in order to ensure that the correct fixture responds to the correct control signal. This digital starting address is the channel number from which the fixture starts to “listen” to the digital control signal sent out from the DMX controller. The assignment of this starting DMX address is achieved by setting the correct DMX address on the digital control display on the fixture.

You can set the same starting address for all fixtures or a group of fixtures, or set different addresses for each individual fixture. Setting all fixtures to the same DMX address will cause all fixtures to react in the same way; in other words, changing the settings of one channel will affect all the fixtures simultaneously.

If you set each fixture to a different DMX address, each unit will start to “listen” to the channel number you have set, based on the quantity of DMX channels of each fixture. That means changing the settings of one channel will only affect the selected fixture. For instance, when this unit is set to 16 Channel mode, you should set the starting DMX address of the first unit to 1, the second unit to 17 (1 + 16), the third unit to 33 (1 + 16 + 16), the fourth unit to 49 (1 + 16 + 16 + 16), etc...

Channel Mode	Unit 1 Address	Unit 2 Address	Unit 3 Address	Unit 4 Address
16Ch	1	17	33	49
18Ch	1	19	37	55

DMX TRAITS

CHANNEL		DMX VALUES	FUNCTION
16Ch	18Ch		
1	1	000 - 255	Pan , 8-bit, 0° - 540°
	2	000 - 255	Pan Fine , 16-bit
2	3	000 - 255	Tilt , 8-bit, 0° - 210°
	4	000 - 255	Tilt Fine , 16-bit
3	5		Color
		000 - 004	White
		005 - 013	White + Color1
		014 - 022	Color1
		023 - 031	Color1 + Color2
		032 - 040	Color2
		041 - 049	Color2 + Color3
		050 - 058	Color3
		059 - 067	Color3 + Color4
		068 - 076	Color4
		077 - 085	Color4 + Color5
		086 - 094	Color5
		095 - 103	Color5 + Color6
		104 - 112	Color6
		113 - 121	Color6 + Color7
		122 - 130	Color7
		131 - 139	White
140 - 195	Clockwise Rotation, fast to slow		
196 - 199	Stop		
200 - 255	Counter-clockwise Rotation, slow to fast		
4	6		Gobo Wheel 1
		000 - 007	Open
		008 - 015	Gobo 1
		016 - 023	Gobo 2
		024 - 031	Gobo 3
		032 - 039	Gobo 4
		040 - 047	Gobo 5
		048 - 055	Gobo 6
		056 - 063	Gobo 7
		064 - 077	Gobo 8
		078 - 085	Gobo 1 Shake, slow to fast
		086 - 093	Gobo 2 Shake, slow to fast
		094 - 101	Gobo 3 Shake, slow to fast
		102 - 109	Gobo 4 Shake, slow to fast
		110 - 117	Gobo 5 Shake, slow to fast
		118 - 125	Gobo 6 Shake, slow to fast
		126 - 133	Gobo 7 Shake, slow to fast
CONTINUED ON NEXT PAGE			

DMX TRAITS

CHANNEL		DMX VALUES	FUNCTION
16Ch	18Ch		
4	6		Gobo Wheel 1 (continued)
		134 - 147	Gobo 8 Shake, slow to fast
		148 - 199	Clockwise Rotation, fast to slow
		200 - 203	Stop
		204 - 255	Counter-clockwise Rotation, slow to fast
5	7		Gobo Wheel 2
		000 - 007	Open
		008 - 017	Gobo 1
		018 - 027	Gobo 2
		028 - 037	Gobo 3
		038 - 047	Gobo 4
		048 - 057	Gobo 5
		058 - 067	Gobo 6
		068 - 077	Gobo 1 Shake, slow to fast
		078 - 087	Gobo 2 Shake, slow to fast
		088 - 097	Gobo 3 Shake, slow to fast
		098 - 107	Gobo 4 Shake, slow to fast
		108 - 117	Gobo 5 Shake, slow to fast
		118 - 127	Gobo 6 Shake, slow to fast
		128 - 189	Clockwise Rotation, fast to slow
190 - 193	Stop		
194 - 255	Counter-clockwise Rotation, slow to fast		
6	8		Gobo 2 Rotation
		000 - 007	Stop
		008 - 129	Clockwise Rotation, fast to slow
		130 - 133	Stop
		134 - 255	Counter-clockwise Rotation, slow to fast
7	9		Prism
		000 - 007	Open
		008 - 099	Prism 1
		100 - 130	Open
		131 - 255	Prism 2
8	10		Prism Rotation
		000 - 007	Stop
		008 - 129	Clockwise Rotation, fast to slow
		130 - 133	Stop
		134 - 255	Counter-clockwise Rotation, slow to fast
9	11	000 - 255	Focus , far to near
10	12	000 - 255	Zoom , minimum to maximum

CONTINUED ON NEXT PAGE

DMX TRAITS

CHANNEL		DMX VALUES	FUNCTION
16Ch	18Ch		
11	13		Shutter
		000 - 003	Off
		004 - 127	Strobe, slow to fast
		128 - 191	Pulse Strobe, slow to fast
		192 - 251	Random Strobe, slow to fast
		252 - 255	Open
12	14	000 - 255	Dimmer , 0% to 100%
13	15		Auto Play
		000 - 024	Off
		025 - 046	Auto Play 1
		047 - 068	Auto Play 2
		069 - 090	Auto Play 3
		091 - 112	Auto Play 4
		113 - 134	Auto Play 5
		135 - 156	Auto Play 6
		157 - 178	Auto Play 7
		179 - 200	Auto Play 8
201 - 255	Color / Gobo Sound Sensitivity		
14	16		Internal Programs (refer to Target Mode section of this manual)
		000 - 010	Off
		011 - 020	Program 1
		021 - 030	Program 2
		031 - 040	Program 3
		041 - 050	Program 4
		051 - 060	Program 5
		061 - 070	Program 6
		071 - 080	Program 7
		081 - 090	Program 8
		091 - 229	Sound Active Sensitivity, minimum to maximum
230 - 255	No Function		
15	17	000 - 255	Pan/Tilt Speed , fast to slow
16	18		Reset
		000 - 021	Off
		026 - 076	Reset Effect (hold 3 seconds)
		077 - 128	Reset Pan/Tilt Motor (hold 3 seconds)
		129 - 255	Reset All (hold 3 seconds)

FUSE REPLACEMENT

Disconnect the unit from its power source. Locate the fuse holder on the underside of the unit, as shown in the diagram below. Use the Philips screwdriver to remove the bad fuse, and replace with a new fuse. ***Always use a fuse of the same T4AL250V rating for replacement.***

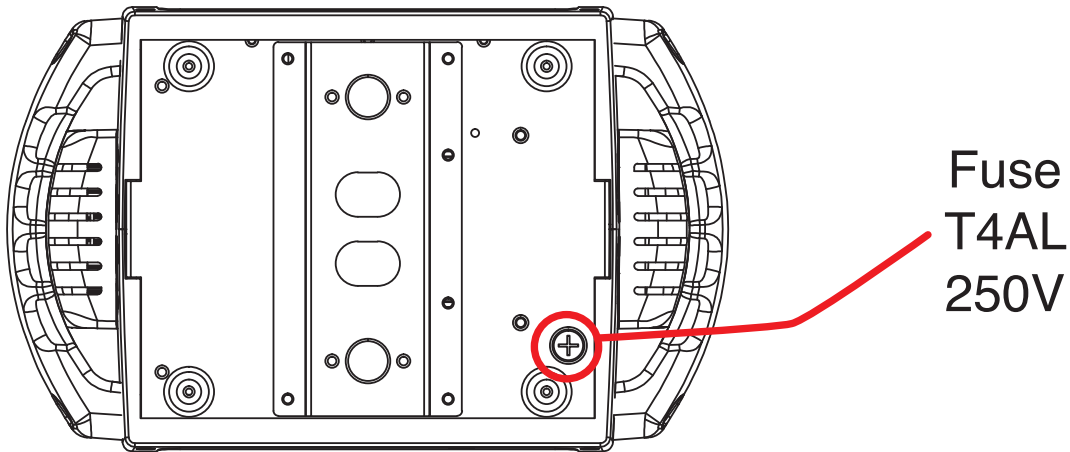

CLEANING

Due to fog residue, smoke, and dust, cleaning the internal and external optical lenses must be carried out periodically to optimize light output.

- Periodically use normal glass cleaner and a soft cloth to wipe down the outside casing and external optics.
- Always be sure to dry all parts completely before plugging the unit back in.

Cleaning frequency depends on the environment in which the fixture operates (i.e. smoke, fog residue, dust, dew).

SPECIFICATIONS

Light Source:

- 150-Watt high power cool white LED
- 50,000 hours average life expectancy

Features:

- Motorized Focus
- Motorized zoom (9° - 14°)
- 0-100% smooth dimming
- Variable speed strobe effect (1Hz - 20Hz)
- Fast, precise, pan & tilt movements

Color Wheel:

- 7 dichroic colors + open white

GOBO Wheels:

- Wheel 1: 8 static GOBOs + Open
- Wheel 2: 6 replaceable rotating GOBOs + Open

Prisms:

- Prism 1: rotatable (bi-directional) 6-facet circular
- Prism 2: rotatable (bi-directional) 5-facet linear

Control:

- Operating modes: DMX512 / Primary-Secondary / Auto Run / Sound Active
- DMX channel modes: 16 / 18
- RDM (Remote Device Management)
- LCD Menu Display

Connections:

- Data in/out: 3-pin DMX
- Locking Input & Output connections to daisy chain power

Pan/Tilt:

- Pan: 540°
- Tilt: 210°
- 16-bit Fine Pan
- 16-bit Fine Tilt

Electrical:

- Multi-voltage operation: 100-240V, 50/60HZ
- Maximum power draw: 180-Watts

Dimensions & Weight:

- Unit Dimensions (LxWxH): 16.4" x 11.5" x 7" / 417mm x 292mm x 180mm
- Weight: 19 lbs. / 8.5kg

Approvals / IP Rating:

- CE
- cETLus (Control# 5027824)
- IP20
- FCC



DIMENSIONAL DRAWINGS

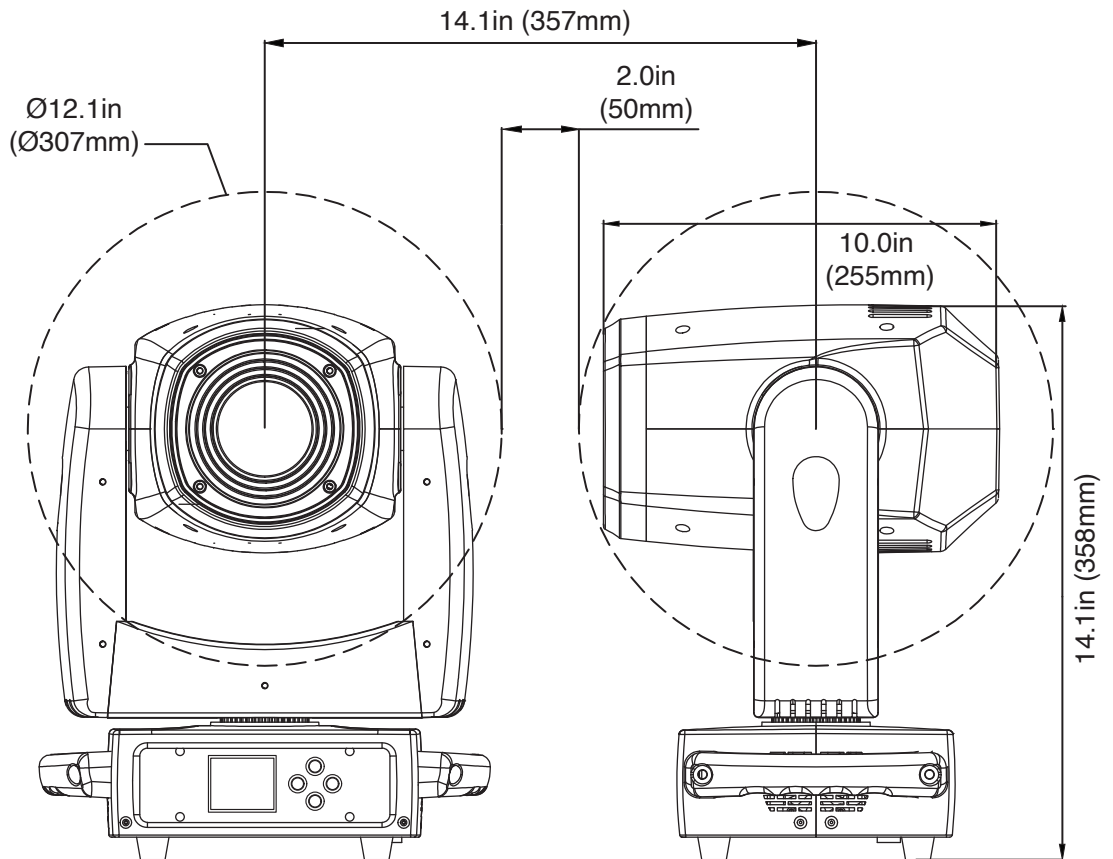
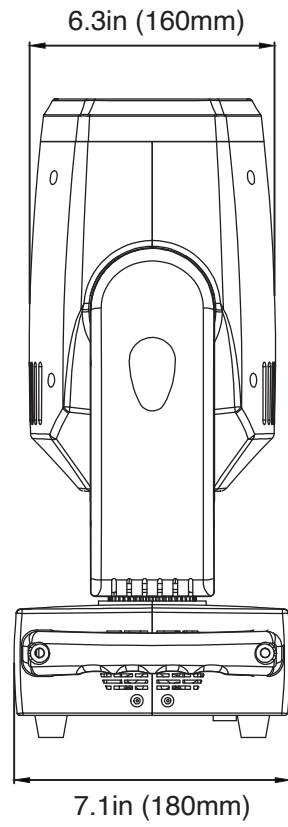
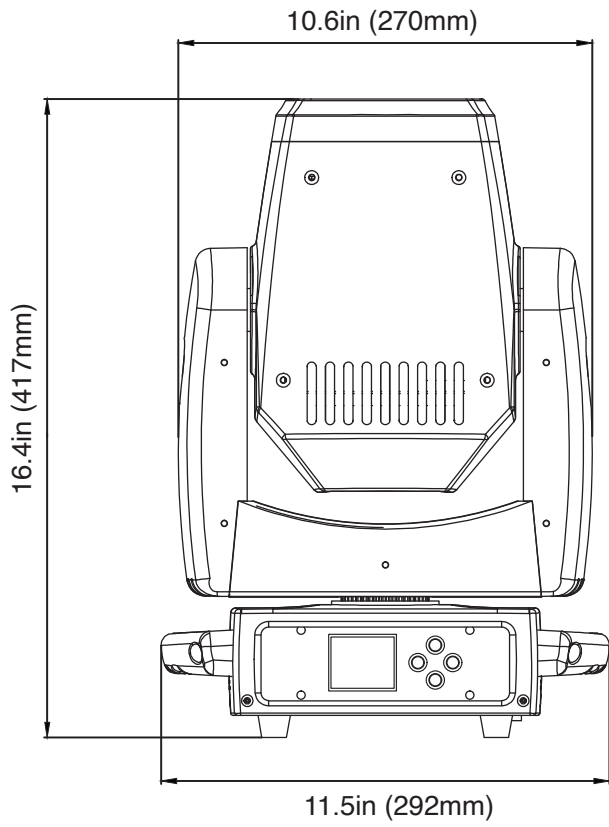

DIMENSIONAL DRAWINGS

OMEGA BRACKET

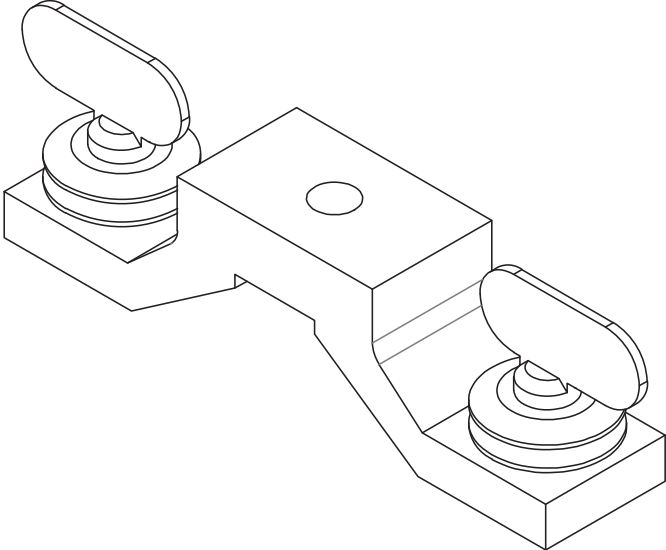
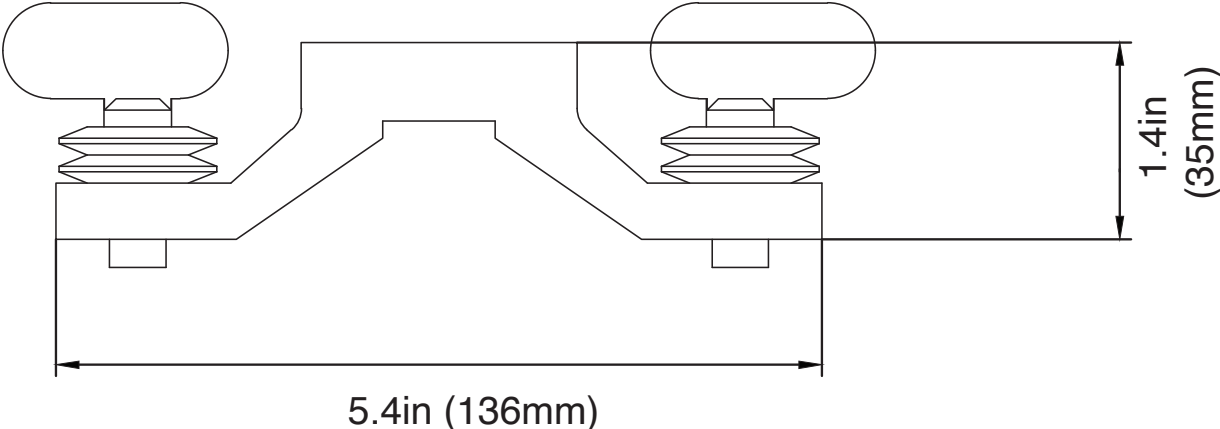

FCC STATEMENT

This device complies with Part 15 of the FCC Rules. Operation is subject to the following two conditions: (1) this device may not cause harmful interference, and (2) this device must accept any interference received, including interference that may cause undesired operation.

Please note that changes or modifications of this product is not expressly approved by the party responsible for compliance could void the user's authority to operate the equipment. NOTE: This equipment has been tested and found to comply with the limits for a Class A digital device, pursuant to part 15 of the FCC Rules. These limits are designed to provide reasonable protection against harmful interference when the equipment is operated in a commercial environment. This equipment generates, uses, and can radiate radio frequency energy and, if not installed and used in accordance with the instruction manual, may cause harmful interference to radio communications. Operation of this equipment in a residential area is likely to cause harmful interference in which case the user will be required to correct the interference at his own expense.

Europe Energy Saving Notice

Energy Saving Matters (EuP 2009/125/EC)

Saving electric energy is a key to help protecting the environment. Please turn off all electrical products when they are not in use. To avoid power consumption in idle mode, disconnect all electrical equipment from power when not in use. Thank you



This page intentionally left blank.

